

ILLUMINATED SWITCHES



FEATURES

- Low profile – 10mm body height
- Mounting pitch 10mm
- Choice of LED colours – red, green, yellow
- PCB mounting – standard 2.5mm pitch
- Alternate or momentary action – choice of modes
- 2 or 4 pole – double throw non-shorting action
- Terminal legs have preforms
- Sealed terminals to avoid flux entry problems

DESCRIPTION

The PVL series is a range of PCB mounted, illuminated switches designed for low current applications such as portable test equipment, instrumentation or other compact devices. The LED is available in a choice of three colours (red, green and yellow). The switch operation may be momentary or alternate.

SPECIFICATIONS

Electrical

Rating	15V DC 0.5A
Contact Resistance	<30mΩ at 20mV DC, 50mA
Insulation Resistance	100MΩ min @ 500V DC
Dielectric Strength	500V AC for 1 minute

Mechanical

Operating Life	>30,000 operations
Operating Temp	-10°C to +60°C
Operating Force	3.0N +/- 1.0N

ORDERING INFORMATION

PVL	4	2	-	02
シリーズ名 Series	回路数 Number of poles	接点数 Number of positions		連番 Serial number
PVL	4 : 4 回路 4 : 4 poles	2 : 2 接点 2 : 2 positions		01 02 ⋮

ILLUMINATED SWITCHES

DIMENSIONS

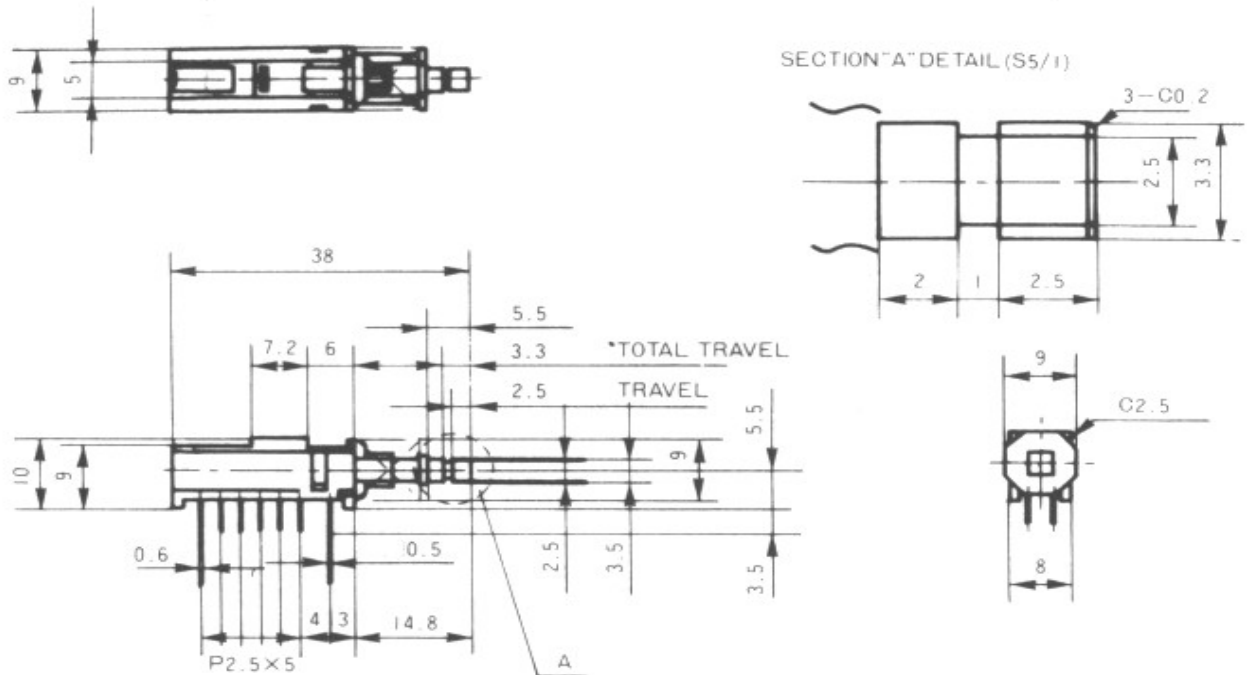
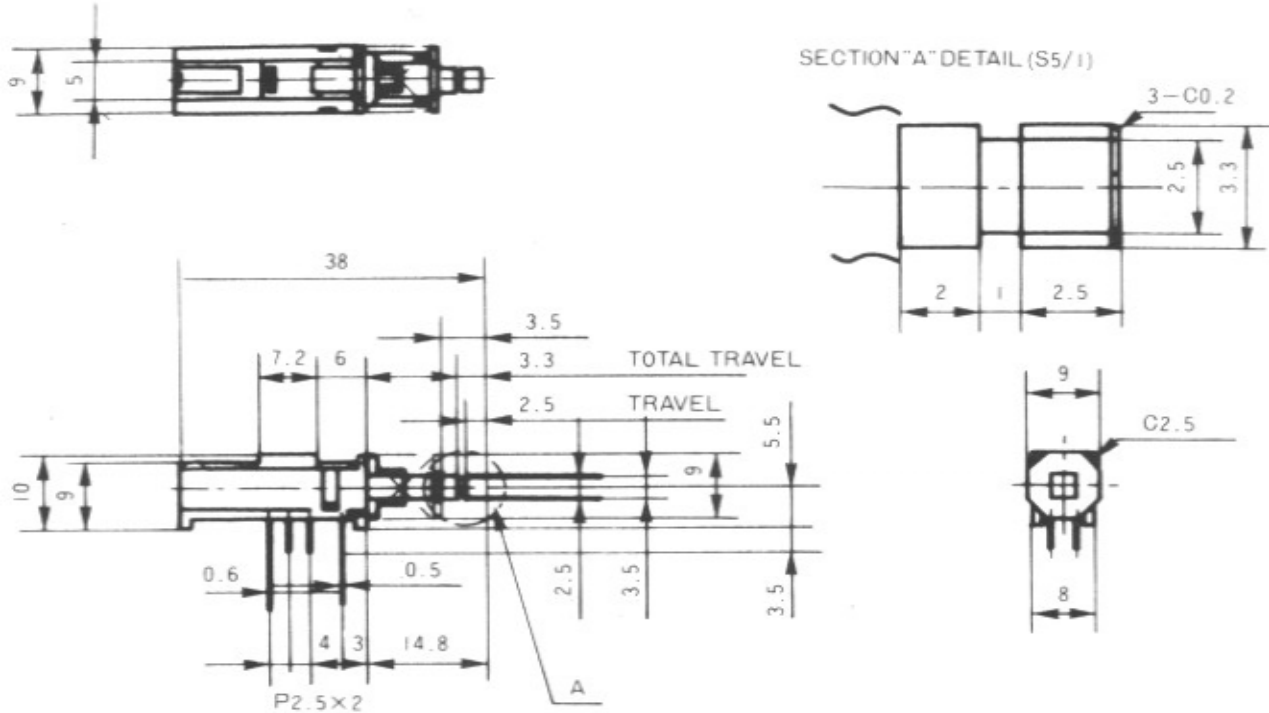

DEVLIN COMPONENTS

Telephone 01256 467367 email sales@devlincomponents.co.uk Website www.devlincomponents.co.uk

